

START OF THD. 0.87 +0.33 / -0.30
 NO. OF TURNS. 2.0
 T. P. I. 12
 THRU BORE MIN. Ø6.5 mm

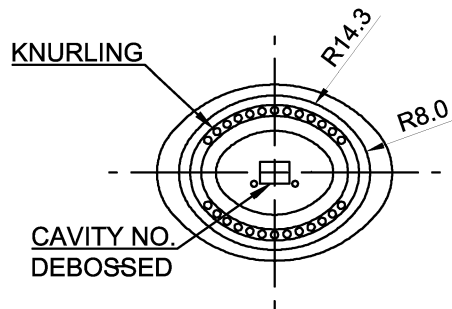
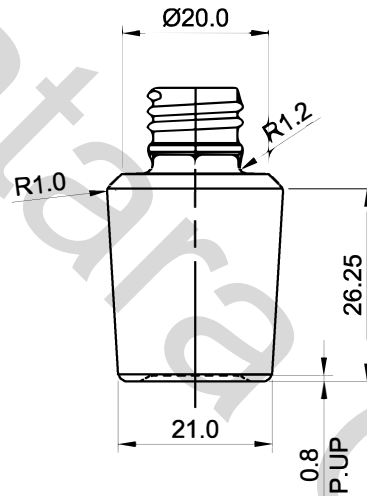
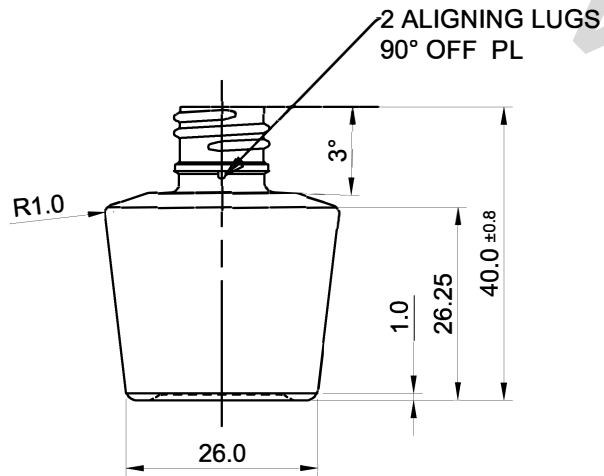
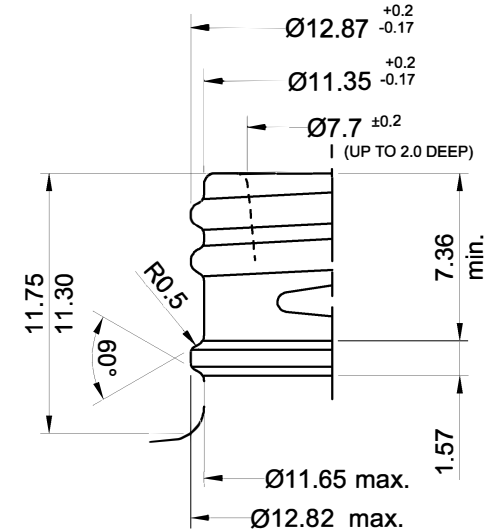

FOR APPROVAL :
CUSTOMER:
SIGN:
NAME:
DATE:

Innovatara GmbH info@innovatara.de +49 (0)2642-40 24 099				WARE		Bottle code :Tina 5ml #527					
<small>ALL DIM'S ARE IN MM DO NOT SCALE DRAWING</small>				<small>SCALE:</small> 1 : 1		<small>DATE</small> 08/08/2016		<small>COLOUR:</small> FLINT		<small>PROD. CATG.:</small> 3FNP	
<small>DES'D BY</small>				<small>DATE:</small> 07.03.'09		<small>OVERFLOW CAP. (ml)</small> 6.2 ± 0.6		<small>FILLING CAP. (ml)</small> ---		<small>WEIGHT (g) (APPROX.)</small> 21.5	
<small>CHK'D BY</small>				<small>APP'D BY</small>		<small>OVERFLOW CAP. (ml)</small>		<small>FILLING CAP. (ml)</small>		<small>NECK FINISH</small> GCM1 13/415/405 PGK NR. REF NO. :- 1889	
<small>REV.NO</small>				<small>REVISION</small>		<small>DATE</small>		<small>SIGN</small>		<small>REV.</small>	